

Simplex Pow'r-Risers Are The Ideal Choice for Railcar & Off-Road Equipment Jacking.



Simplex Pow'r-Risers™ are used to pick up the largest earth haulers in the world. "We use the Simplex jack due to its easy transport and the many optional extensions and lock rings that gives us the safe use required in mining operations."



Model Number	Capacity (tons)	Min. Height (in.)	Stroke (in.)	Motor	Max. Additional Stack Ht. Using Optional Extension System	Control Valve	Power Source	Noise Level (Db)	Weight (lbs.)						
JA6024	60	24	14	Air	32*	Manual	Air Motor 50 CFM 80 PSI	89	390						
JA6037		37	27							Electric	115 VAC 50/60 Hz 20 amps	80	600		
JE6024		24	14	Air			21**	Manual	50 CFM 80 PSI					510	
JE6037		37	27							Electric	115 VAC 50/60 Hz 20 amps	80	600		
JA10026	100	26	16	Air	21**	Remote 20' Pend.			50 CFM 80 PSI					510	
JA10037		37	27							Electric	115 VAC 50/60 Hz 20 amps	80	600		
JAS10026		26	16				Manual	230/460 VAC 3 Phase	510					530	
JAS10037		37	27							Air	Air Motor 50 CFM 80 PSI	89	600		
JE10026		26	16	Electric		115 VAC 50/60 Hz 20 amps		80	600						
JE10037		37	27							Air	Remote 20' Pend.	50 CFM 80 PSI	708		
JEB10026		26	16			Electric	115 VAC 50/60 Hz 20 amps	80	570						
JEB10037		37	27							Air	Manual	230/460 VAC 3 Phase	590		
JAS15026	150	26	15 1/2	Air	21**		Remote 20' Pend.	50 CFM 80 PSI	708						
JAS15037		37	26 1/2							Electric	115 VAC 50/60 Hz 20 amps	80	708		
JE15026		26	15 1/2			Manual		230/460 VAC 3 Phase	570					728	
JE15037		37	26 1/2							Air	Air Motor 50 CFM 80 PSI	89	640		
JEB15026		26	15 1/2	Contact Factory			Remote 20' Pend.	50 CFM 80 PSI	89					825	
JEB15037		37	26 1/2							Air	Contact Factory	Remote 20' Pend.	89		640
JAS20026		200	26			15 1/2									
JAS20037			37			26 1/2				Air	Contact Factory	Remote 20' Pend.	89		825

* Based on (1) 18" and (1) 11" extension and (1) 3" spacer.

**Based on (1) 18" extension and (1) 3" spacer.

WARNING: Any two extensions may be stacked for loads up to 60 tons per jack. For loads from 60 tons to 150 tons only 1 extension and 1 spacer can be used.

NOTHING ELSE IS EASIER OR SAFER:

- 24", 26" & 37" Minimum Heights.
- 60, 100, 150 & 200 ton capacities to handle the toughest jobs.
- Sup'r-Stack™ extension system gives the jack a wide variety of minimum heights.
- 3 position handle for easy tilt back and rolling.
- 4" of ground clearance for rough terrain.
- Mechanical lock rings for fail safe holding.
- Easy to change external filter minimizes down time.
- Only 24" wide/fits in tight spots.
- Air pilot or 12 VAC pendant with 6 meter cord for remote operator safety.
- Dual hydraulic locking systems prevent creep down.
- Equipped with a pilot-operated check valve which locks the load in place to prevent accidental lowering.

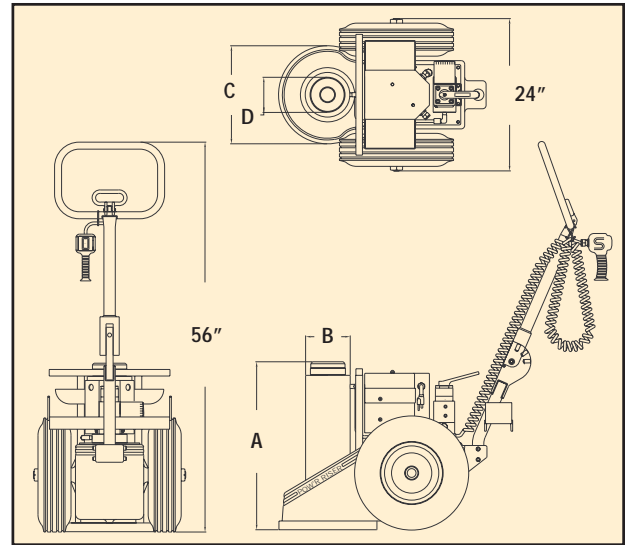

Model Number	"A" (in)	"B" (in)	"C" (in)	"D" (in)
JE6024	24	6.38	14	4
JE6037	37	6.38	14	4
JE10026	26	7	18	4
JE10037	37	7	18	4
JE15026	26	8	18	5
JE15037	37	8	18	5
JAS20026	26	10	18	6
JAS20037	37	10	18	6



NOTHING ELSE COMES CLOSE:

- Rugged, fully enclosed frame; no exposed fittings or hoses.
- Runs on air or 115 or 230VAC, 15 amp service.
- Secondary back-up filtration system for reliability.
- Light weight for greater mobility and less back strain.
- Optional dual porting for use with remote cylinders.
- Automatically controlled, "chatter free" load lowering for maximum safety in descent.
- All Pow'r-Riser II™ models comply with ASME/ANSI B30.1 Specifications.

The Simplex Pow'r-Riser II, When Used With Sup'r-Stack™ Extension Set and Spacer Set, Can Handle All Rail Cars and Off-Road Equipment Without Blocking.

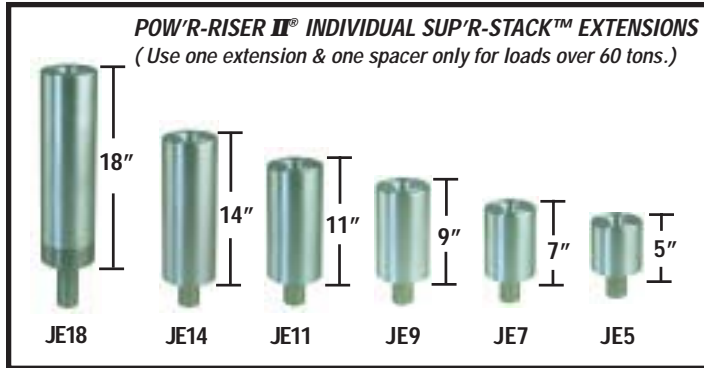

ES6024 Extension Set

Model Number	Description
JE5	5" Extender
JE7	7" Extender
JE11	11" Extender
JE18	18" Extender



Swivel Load Cap

Model Number	Description
JTS60	60 & 100 ton
JTS150	150 ton

Min. & Max. Height For Lifting Can Be Achieved By Using The Following Spacer/Extender Combination

Min. Height	25	26	27	29	30	31	32	33	34	35	36	37	38	40	42	43	44	45	47	48	49	50	51	52	53	54	55	56
Ext. Height	39	40	41	43	44	45	46	47	48	49	50	51	52	54	56	57	58	59	61	62	63	64	65	66	67	68	69	70
Spacer					+1		+1	+2	+3		+1	+2	+3	+5		+1	+2	+3	+5	+1	+7	+1	+2	+3	+11	+1	+2	+3
Drop-In Extender Combination	1	2	3	5	5	7	7	7	7	11	11	11	11	11	18	18	18	18	18	+5	+18	+7	+7	+7	+18	+18	+18	+18

Use tallest extender on the bottom.

POW'R-RISER II® SPACER SET - JS4



JS-3 JS-2 JS-1 (Qty. - 2)

Fine tune your extension stack height by adding 1", 2" or 3" spacer.

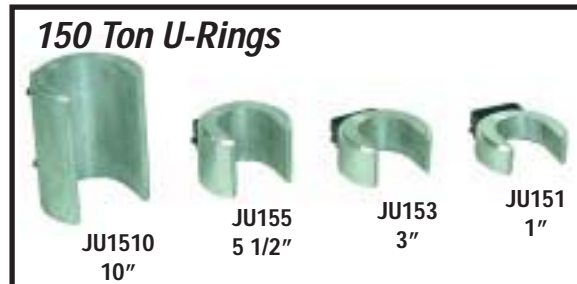
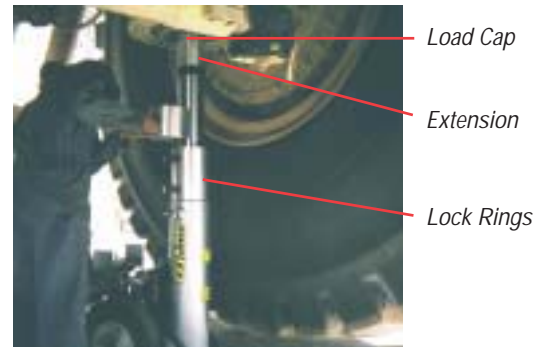
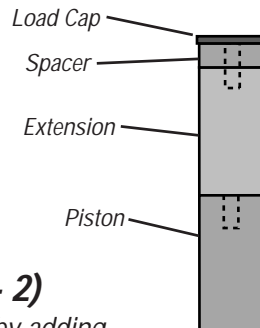

POW'R-RISER II® LOCKING U-RING SETS

Model Number	Models Used On	Contains
JUS126	60 Ton 24"/100 Ton 26"	(2) JU11 - 1", (1) JU13 - 3", (2) JU14 - 4 1/4"
JUS137	60 Ton 37"/100 Ton 37"	(2) JU11 - 1", (1) JU13 - 3", (2) JU14 - 4 1/4", (1) JU110 - 10"
JUS1526	150 Ton 26"	(2) JU151 - 1", (1) JU153 - 3", (2) JU155 - 5 1/2"
JUS1537	150 Ton 37"	(2) JU151 - 1", (1) JU1510 - 10", (2) JU155 - 5 1/2"
JUS20026	200 Ton 26"	(2) JU201 - 1", (1) JU203 - 3", (2) JU205 - 5 1/2"
JUS20037	200 Ton 37"	(2) JU201 - 1", (1) JU2010 - 10", (2) JU205 - 5 1/2"